

SPECIFICATIONS	Model	80C22.2-CR							
		C(CR)-series 2.2kW, 3-phase							
<p>Type of Pump Submersible cast iron pump with a cutting device suitable for pumping sewage and wastewater</p> <p>Type of Fluid Sewage, wastewater, and water carrying solid matters</p> <p>Temperature: 0 to 40°C (High temperature model available on special request)</p> <p>Discharge Bore 80mm</p> <p>Motor Output 2.2kW</p> <p>Power Supply Three-phase</p> <p>Starting Method Direct on Line</p> <p>Motor Continuous-duty rated, dry-type induction motor</p> <p>Insulation Class: F Degree of Protection: IP68</p> <p>No. of Poles & Speed (Synchronous Speed) 2-pole, 3000/3600min⁻¹ (50/60Hz)</p> <p>Power Supply Voltages & Rated Currents</p> <table border="0"> <tr> <td>50Hz</td> <td>60Hz</td> </tr> <tr> <td>380V – 5.3A</td> <td>220V – 9.0A</td> </tr> <tr> <td>400V – 5.2A</td> <td>380V – 5.6A</td> </tr> <tr> <td>415V – 5.2A</td> <td>440V – 5.0A</td> </tr> </table> <p>Power Cable Sheath: PVC Standard Length: 10m 200 to 600V supply: 1 × 4 × 2.0mm², O.D. 11.8mm</p> <p>Dry Weight (excluding cable) Free Standing Type: 77kg Guide Rail Fitting Type: 68kg</p>	50Hz	60Hz	380V – 5.3A	220V – 9.0A	400V – 5.2A	380V – 5.6A	415V – 5.2A	440V – 5.0A	<p>Impeller Semi-open two-channel impeller for solid-handling design, made of high-chromium cast iron, dynamically balanced. A sintered tungsten carbide alloy edge is blazed on each impeller vane.</p> <p>Solids Passage 50Hz – 22 × 31mm 60Hz – 20 × 31mm</p> <p>Cable Entry with Anti-Wicking Block Watertight cable entry with strain-relief device. The anti-wicking block prevents water incursion due to capillary action should the power cable be damaged or the end submerged.</p> <p>Bearings Permanently lubricated, deep-groove, double-shielded C3 ball bearings</p> <p>Shaft 420 stainless steel</p> <p>Shaft Seal (Mechanical Seal) Furnished with a double-face mechanical seal located in oil chamber. Both upper and lower seal faces always run in a clean environment.</p> <p>Upper Seal Faces: SiC + SiC Lower Seal Faces: SiC + SiC</p> <p>Oil Seal (Lip Seal) Used as a “Dust Seal”, it protects the mechanical seal from abrasive particles.</p> <p>OIL LIFTER (Patented) Equipped in oil chamber. It forcibly supplies lubricating oil to the mechanical seal and continues to supply the oil to the upper seal faces even if lubricant falls below the rated volume.</p> <p>Type of Lubricating Oil & Volume Turbine Oil (ISO VG32), 1890ml</p> <p>Motor Protection Device A circle thermal protector built in the motor housing. Directly cuts the motor circuit if excessive heat builds up or an overcurrent condition occurs in the motor.</p>
50Hz	60Hz								
380V – 5.3A	220V – 9.0A								
400V – 5.2A	380V – 5.6A								
415V – 5.2A	440V – 5.0A								
<p>Optional Accessories</p> <p>Bend Set (Free Standing Type)</p> <ul style="list-style-type: none"> • Discharge Bend • JIS 10kg/cm² Screwed Flange <p>TOS Set (Guide Rail Fitting Type)</p> <ul style="list-style-type: none"> • Duckfoot Bend • Guide Support • Guide Hook • Lifting Chain 5m (with Shackles) • JIS 10kg/cm² Screwed Flange <p>External Leakage Sensor</p>									
TSURUMI MANUFACTURING CO., LTD.									

NO. J4-34313-1

PUMP PERFORMANCE CURVES

TYPE	Submersible High Head Cutter Sewage Pump	MODEL	80C22.2-CR-61 TOS80C22.2-CR-61	FREQUENCY	60 Hz
------	---	-------	-----------------------------------	-----------	-------

CUSTOMER'S NAME _____

EQUIPMENT TITLE _____

NO. _____

	STANDARD SPECIFICATIONS	REQUIRED SPECIFICATIONS
DISCHARGE BORE	mm	80 mm
TOTAL HEAD	m	MAX. 22 m
CAPACITY	m ³ /min	MAX. 0.9 m ³ /min
MOTOR OUTPUT	kW	2.2 kW
PHASE × VOLTAGE	φ × V	3 φ × V
CURRENT	A	A
POLES / REVOLUTION	P / min ⁻¹	2 P / S. S. 3600 min ⁻¹
STARTING METHOD		DIRECT ON LINE
INSULATION CLASS		F

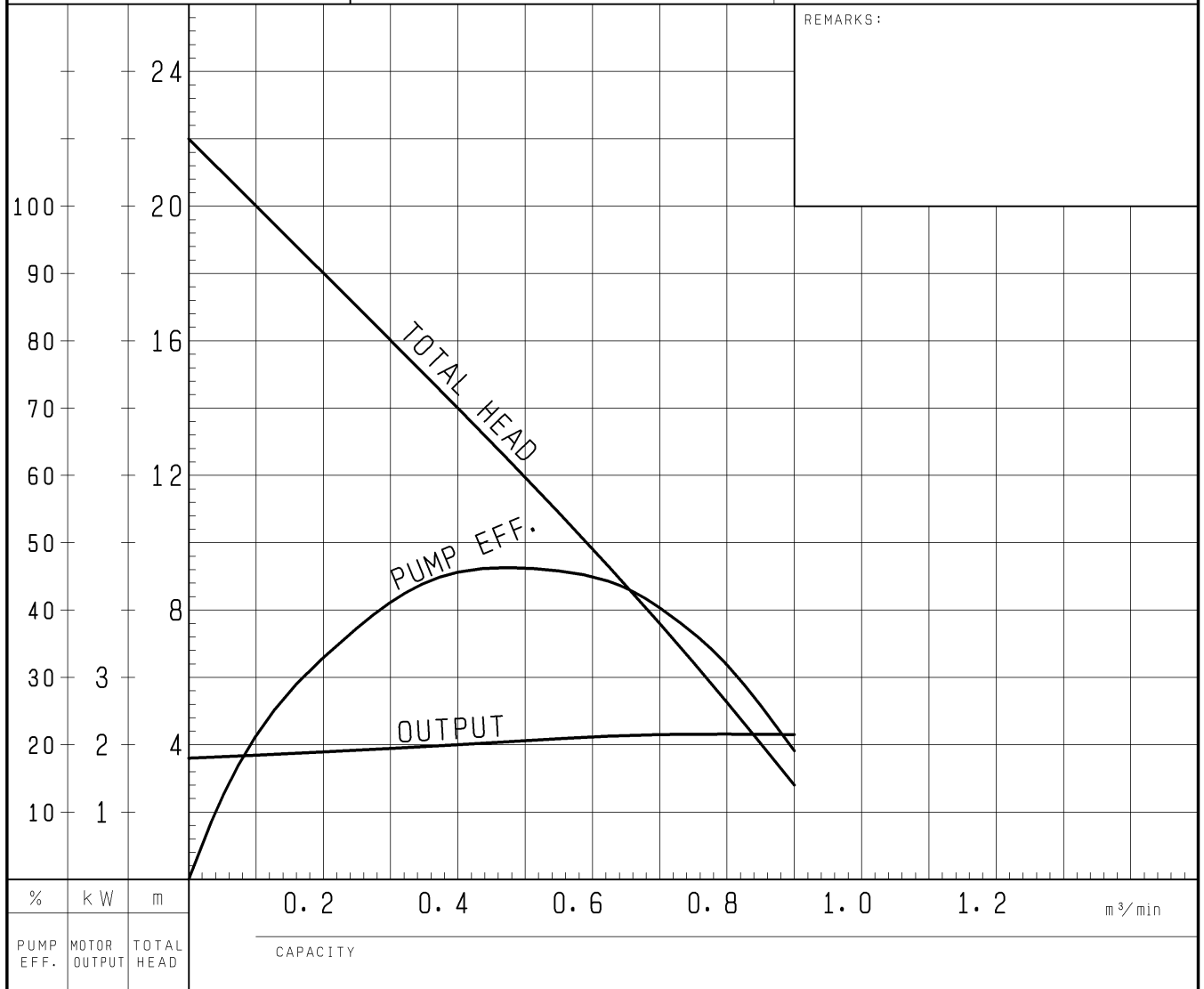

TSURUMI MFG. CO., LTD.

DIMENSION DRAWING		No.	No. J4-34338-1
TYPE	Submersible High Head Cutter Sewage Pump	MODEL	80C22.2-CR -51/61

Approximate Weight (※)	
Discharge Bend	Pump
12kg	65kg
※excluding cable	

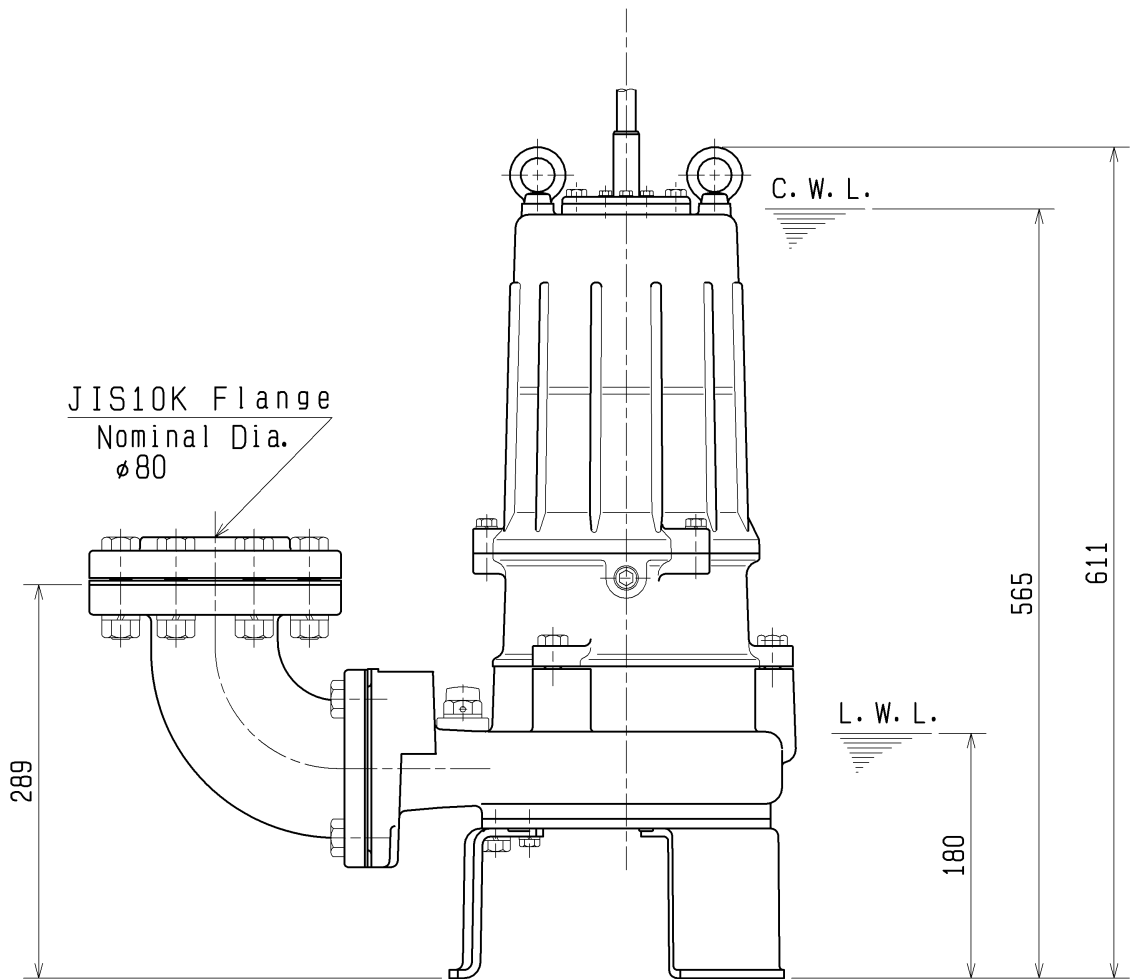
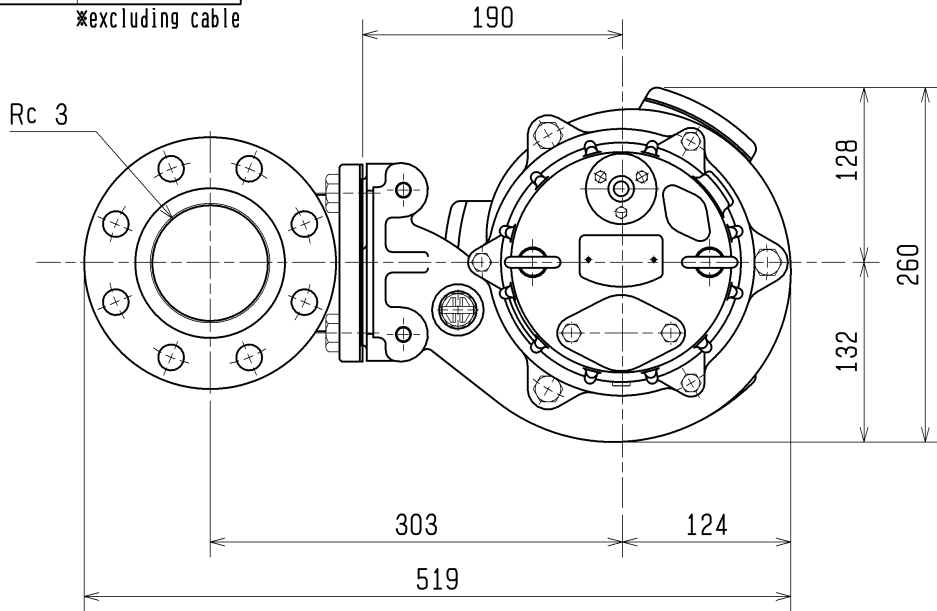

C. W. L. :Continuous Running Water Level.
L. W. L. :Lowest Running Water Level.

SECTIONAL DRAWING		No.	No. J4-34339-1
TYPE	Submersible High Head Cutter Sewage Pump	MODEL	80C22.2-CR -51/61

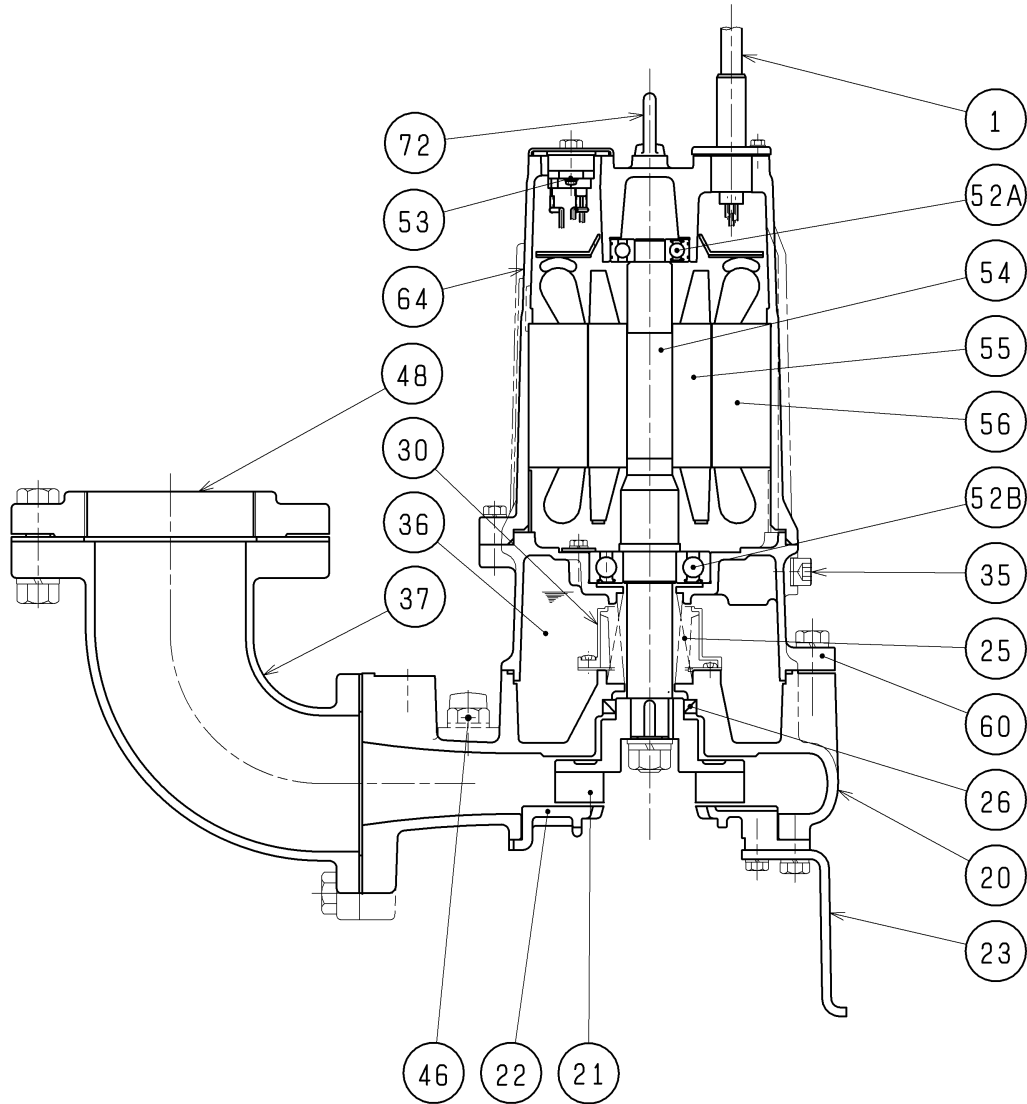

REQ. SPECIFICATION

No.	DESCRIPTION	Q'TY	MATERIAL / NOTE	No.	DESCRIPTION	Q'TY	MATERIAL / NOTE
1	Cable	1	PVC Sheath	52B	Lower Bearing	1	6307ZZC3
20	Pump Casing	1	Gray Iron Casting	53	Motor Protector	1	
21	Impeller	1	Chromium Iron Casting (WC Edge)	54	Shaft	1	Stainless Steel 420J2
22	Suction Cover	1	Chromium Iron Casting	55	Rotor	1	
23	Stand	3	Structure Steel	56	Stator	1	
25	Mechanical Seal	1	H-30	60	Bearing Housing	1	Gray Iron Casting
26	Oil Seal	1	TC45629	64	Motor Frame	1	Gray Iron Casting
30	Oil Lifter	1	Plastic	72	Eye Bolt	2	Stainless Steel 304
35	Oil Plug	1	Stainless Steel 304				
36	Lubricant		Turbine Oil (ISO VG32)				
37	Discharge Bend	1	Gray Iron Casting				
46	Air Release Valve	1	Nylon				
48	Screwed Flange	1	Gray Iron Casting				
52A	Upper Bearing	1	6304ZZC3				